

Triflex

Delivering solutions together.

CAR PARK REFURBISHMENT
GATESHEAD

GATESHEAD COLLEGE BAL TIC CAMPUS

CASE
STUDY

Authorised Contractor:
Mike Thelwell Flooring Ltd

Area
1,900m²

Systems
Triflex ProPark®
Triflex ProTect®
Triflex ProDetail®
Triflex ProFibre

☎ 01785 819119

🌐 triflex.co.uk

✉ info@triflex.co.uk

🌐 Triflex (UK) Ltd

🐦 @TriflexUK

Triflex (UK) Ltd. | Whitebridge Way | Stone | Staffordshire | ST15 8JS

Introduction

Gateshead College, Baltic Campus is served by a busy 225 space multi-storey car park. Restoration and waterproofing of the car park's exposed upper decks was required to protect the underlying structure, following failures in the existing coating. To meet funding allocation, the project was required to meet exacting timescales.

The challenge

Gateshead College faced a number of issues resulting from a failing and delaminating coating on the upper decks of the multi-storey car park at the Baltic campus. Surface damage and cracking to the concrete substrate, together with water ingress to the lower decks, was evident. This was most likely caused by the failed coating.

The multi-storey car park consists of a structural steel frame supporting precast reinforced concrete units, with a structural concrete topping. The upper storey comprised of a split-level inclined deck, allowing parking on the inclines with adjacent high wear turning areas. A heating loop was buried in the surface of the inclined deck to combat snow and ice, enabling safe parking and pedestrian use all year round.

Careful consideration was required for the heating loop to ensure continued performance. The upper decks were naturally exposed to the extremes of weather. Repairs, together with a robust, proven system was required to address the movement, cracking and water ingress.

Gateshead College also had exacting timescales for the project completion to ensure funding allocation. In addition, the college required a supplier able to offer reassurance through secure financial footing and a meaningful warranty.

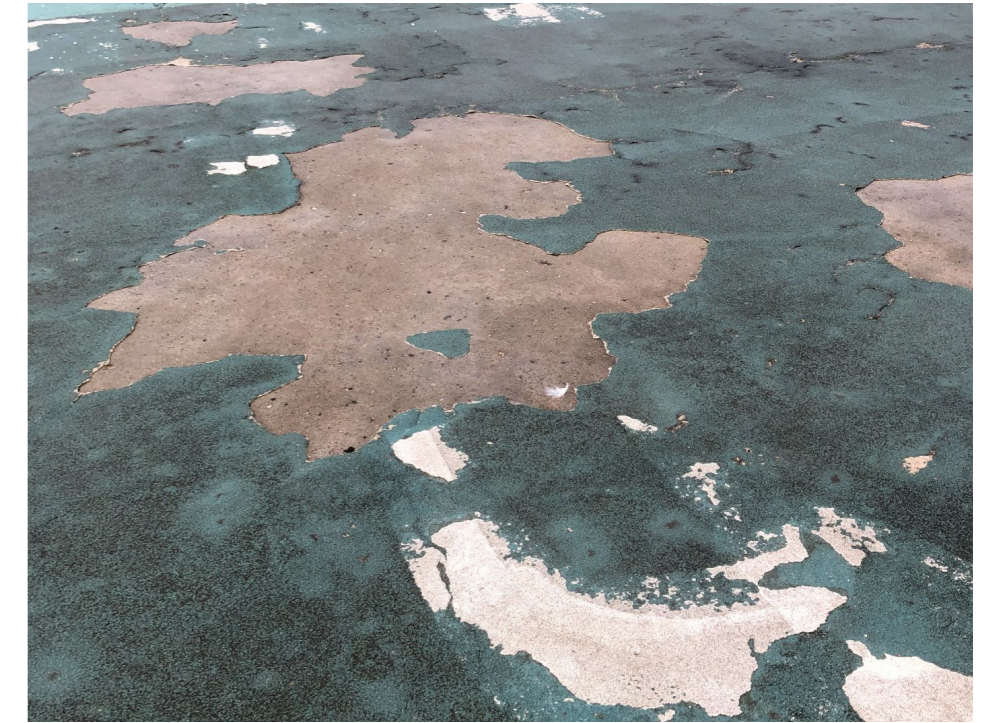

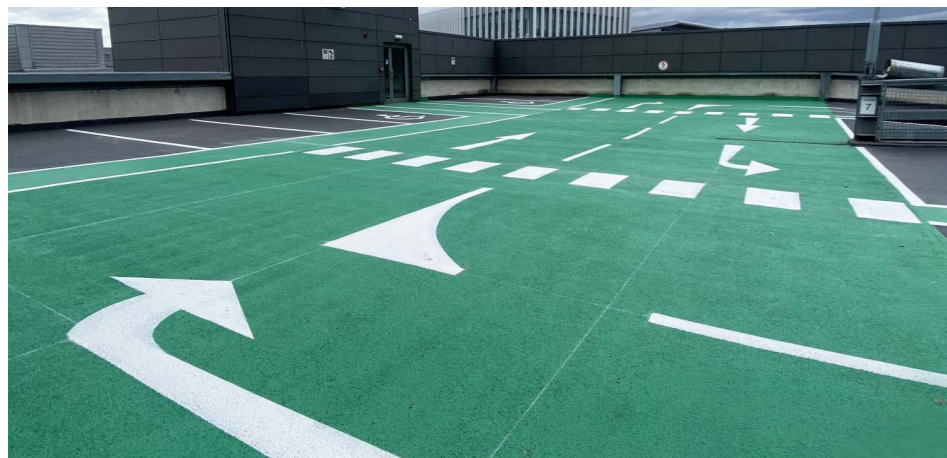

The solution

The existing car park concrete structure and failing coatings were assessed by our highly experienced technical support team. Following a detailed site survey and testing to determine the quality and suitability of the concrete substrate for overlay, the Triflex technical team were able to provide a project specification proposal to the client using the fully reinforced Triflex ProPark® system.

Composite car parks are subject to high levels of movement and the Triflex ProPark system is designed specifically for external decks at high risk of cracking. In such structures dynamic cracking over beams is commonplace due to deflections within the precast units, rotation over beams and differential properties between the precast units. The Triflex ProPark system is BBA certified and delivers the highest class of dynamic crack bridging under EN 1504-2 and at B 4.2 (-20°C). Triflex extensive experience has demonstrated that our reinforced systems provide long term waterproofing integrity, even under such demanding conditions.

The cohesive on-site tests undertaken helped to determine the required surface preparation and priming requirements for the application of the Triflex ProPark system across the 1900m² surface. The existing failing system needed to be removed and the surface prepared by careful planing followed by enclosed shot blasting. Thanks to the dynamic crack bridging properties, the versatile Triflex ProPark was used for over banding to reinforce and offer protection over all cracks, prior to surface overlay with the Triflex ProPark system.

It's properties of being tough, durable, impact and highly abrasion resistant, as well as high levels of resistance to petrol, diesel, brake fluid, engine oil, battery acid, de-icing salts and cleaning chemicals provided reassurance of its longevity for the campus. And as the Triflex ProPark is completely hydrolysis resistant, even ponding water poses no threat of degradation.

“We found working with Triflex a very positive experience. As well established, knowledgeable experts, Triflex identified the issues and were clear about the resolution and project delivery, giving us confidence in all aspects of the restoration. And, collaborating with the Triflex Authorised Contractor, the project was completed within the exacting timescales. Triflex provided added reassurance with their robust warranty, giving us peace of mind for the future too.”

Steve Collingwood, Facilities Manager, Gateshead College.



The solution

The Triflex ProPark with quartz was used for the parking areas providing a robust anti-skid surface. Triflex ProPark with Emery was used for the inclined driving aisles and hammerhead turns for maximum anti-skid and high retention of PTV over time.

The system was applied in traffic green and traffic grey providing demarcation for enhanced driver and pedestrian wayfinding. Each application is fully cured within the hour, meaning that the whole system was delivered rapidly. Finally, surface markings were applied using Triflex Preco Line 300, in white and yellow providing a crisp finish.

Self-terminating Triflex ProFibre was used on awkward penetrations and lamp post mounts, and Triflex ProDetail® was used on upstands, its thixotropic formula enabling rapid robust waterproofing to this area.

The roofs of the stairwell structures were also waterproofed with Triflex ProTect®, another rapid curing, reinforced PMMA system designed for waterproofing flat roof constructions. Here, the existing single ply membrane was overlaid for a cost effective and sustainable repair.

The project works met the college's exacting timelines, making sure that both the term time restriction and budget spend timescales were achieved. All works were carried out to a very high standard by Mike Thelwell Flooring Ltd, supported by Triflex. Triflex have provided protection systems for the built environment for over 40 years and offer meaningful secure warranty, ensuring peace of mind for Gateshead College.

System benefits
Triflex ProPark®

- Totally cold applied, with no risk from hot works
- Compatible with virtually all roof substrates
- Dynamic crack bridging
- Exceptionally rapid curing / rainproof times, even at low temperatures
- Fully reinforced waterproofing technology
- Tough and durable protection
- Can overlay asphalt
- High levels of anti-skid resistance
- Environmentally safe (solvent and isocyanate free)
- Comes in a range of standard and bespoke colours

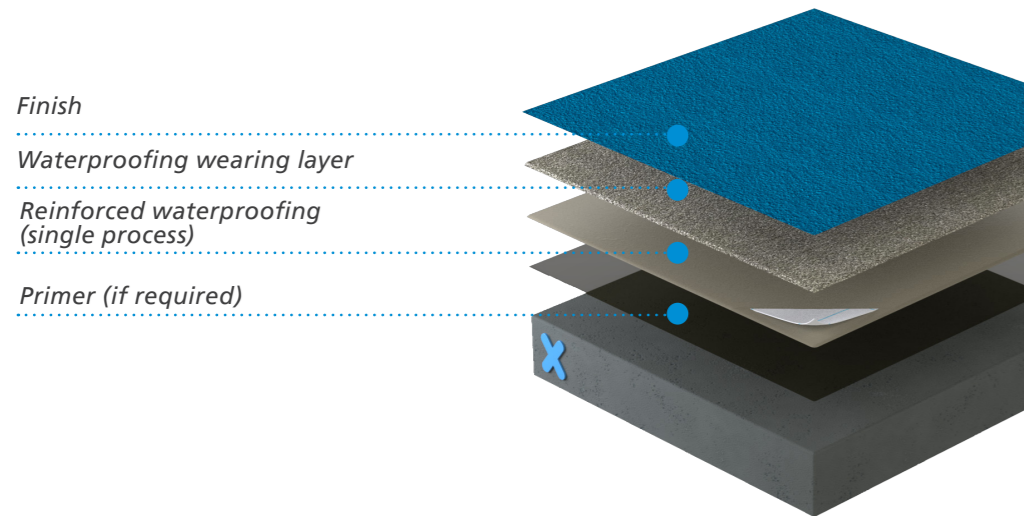

System benefits
Triflex ProTect®

- Totally cold applied, with no risk from hot works
- Compatible with virtually all roof substrates
- Suitable for all roof build-ups and applications
- Exceptionally rapid curing / rainproof times, even at low temperatures
- Fully reinforced waterproofing technology
- Suitable for zero pitch, completely flat and pitched roofs
- Simple, single process waterproofing application
- Hydrolysis (standing and ponding water) resistant

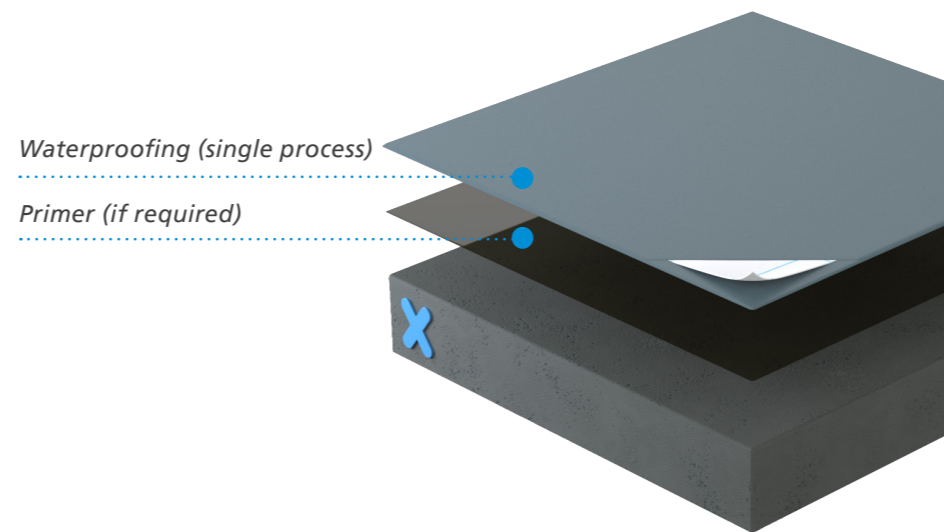

System benefits
Triflex ProDetail®

- Waterproof down to the smallest detail
- Compatible with virtually all substrates including asphalt
- Cold applied, fast curing with rapid installation
- Simple, single process waterproofing application
- Rapid curing system - even at low temperatures
- Fully reinforced technology
- Certified to the highest standards

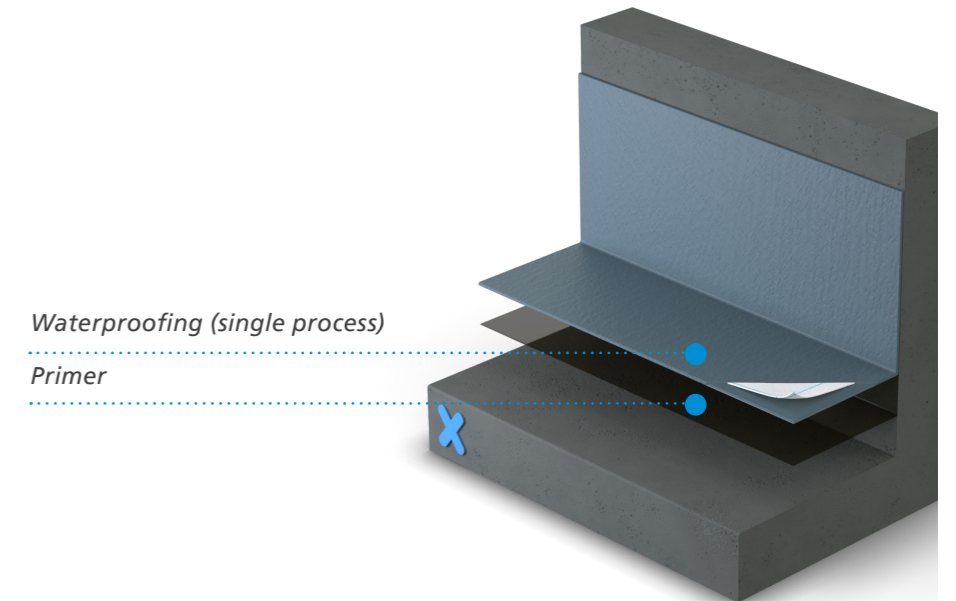

System benefits

Triflex ProFibre®

- Waterproof down to the smallest detail
- Compatible with virtually all substrates including asphalt
- Cold applied, fast curing with rapid installation
- Simple, single process waterproofing application
- Rapid curing system - even at low temperatures
- Fully reinforced technology

Reinforced waterproofing

Primer

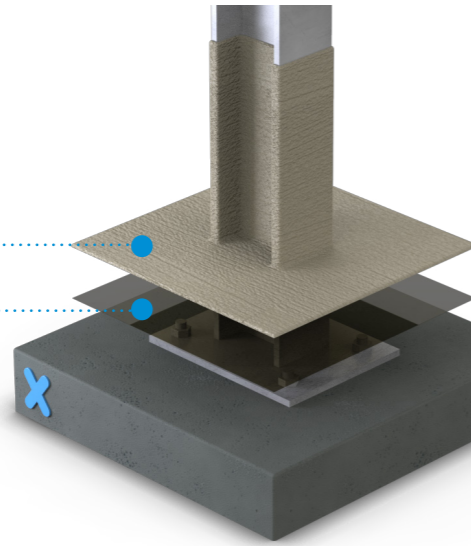

Triflex

Delivering solutions together.

Triflex is the leading European specialist in cold liquid applied waterproofing, surfacing and marking resins. Our high-quality systems provide reliable and lasting waterproofing, surfacing, protection and markings for roofs, walkways, balconies, terraces, car parks, roads and infrastructure.

We are a family owned and operated company that provides tailored solutions worldwide. From our production facilities based in Minden, Germany, we have been researching and developing solutions designed to protect and repair the built environment for more than 40 years.

From our UK and Ireland headquarters based in Stone, Staffordshire we pride ourselves on providing our clients with tailored solutions and exceptional levels of service and support throughout all stages of their project. From conducting in-depth site surveys to our comprehensive testing and off-site and on-site support, we ensure that your project is completed on time, expertly. Triflex solutions are certified to the highest standards and are backed up by long-term meaningful warranties, ensuring peace of mind for years to come.

☎ 01785 819119

🌐 triflex.co.uk

✉ info@triflex.co.uk

🌐 Triflex (UK) Ltd

🐦 @TriflexUK

Triflex (UK) Ltd. | Whitebridge Way | Stone | Staffordshire | ST15 8JS